

**AC MOTOR DIMMER 1000 WATT**  
CODE 420 **LEVEL 1**

Fan control circuit controls fan's speed. It can control those electrical equipments for maximum 1000 watts.

**Technical specifications:**

- voltage supply: 220-240VAC.
- maximum load: 1000 watts @ 220VAC
- speed adj. by potentiometer
- PCB dimensions : 1.01 x 1.82 inches.

**How to works:**

TRIAC acts as switch, controlled by the gate. DIAC starts current at the gate of TRIAC and makes TRIAC conducts current (30-32V). To start current at the gate of TRIAC, R1, VR1, C1 will delay time. As per figure 2 and 3, C1 charges 30-32V current, which is delay position. 1st and 3rd period are TRIAC positions that conduct current. Figure 2 shows VR1 adjusting position in order to be at center. C1 can charge current within half cycle. So that TRIAC current conducting time will be reduced to only half cycle. So than electrical power to be reduced accordingly. Figure 3 shows the adjusted position of VR1 to be high resistance, so conducting time of C1 is longer and conducting time of TRIAC is reduced, electrical power is reduced accordingly. But if we turn VR1 to have maximum resistance, charge period of C1 will be longer till no conducting period, so TRIAC does not conduct current and there is no electrical power out at all.

**PCB assembly:**

Shown in Figure 5 is the assembled PCB. Starting with the lowest height components first, taking care not to short any tracks or touch the edge connector with solder. Some tracks run under components, and care should be taken not to short out these tracks. All components with axial leads should be carefully bent to fit the position on the PCB and then soldered into place. Make sure that the electrolytic capacitors are inserted the correct way around. The LED has a flat spot on the body which lines up with the line on the overlay. Now check that you really did mount them all the right way round!

**Testing:**

Following figure 5. Using lesser than 300 watts light

bulb for "OUT" point. Turning VR1 max. counter-clockwise, light bulb will shut down. Turning VR1 max. clockwise, light bulb will be lighted respectively to maximum. LED will also display according to VR1 adjustment.

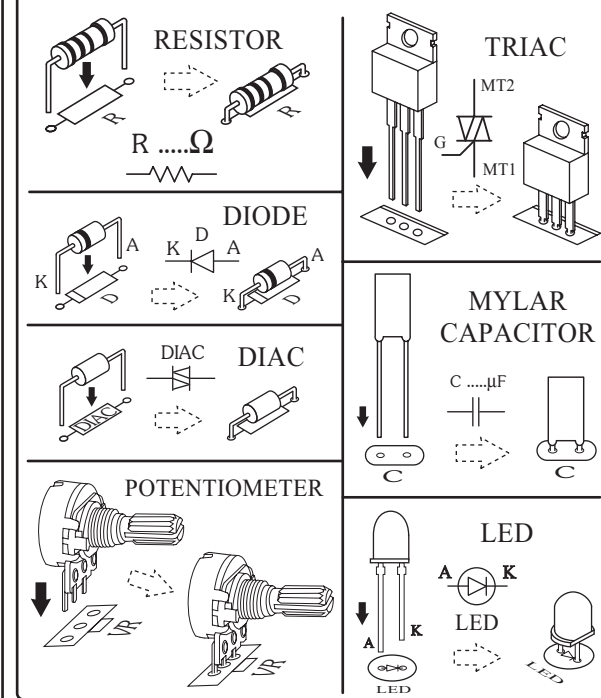
**Application:**

Connecting "IN" point with male plug and "OUT" point with female plug. Using plastic doorknob for VR1 and plastic box. If apply for over 300 watts, TRIAC should have heat sink. It requires at least 0.5 mm. electrical wire.

**Remark:**

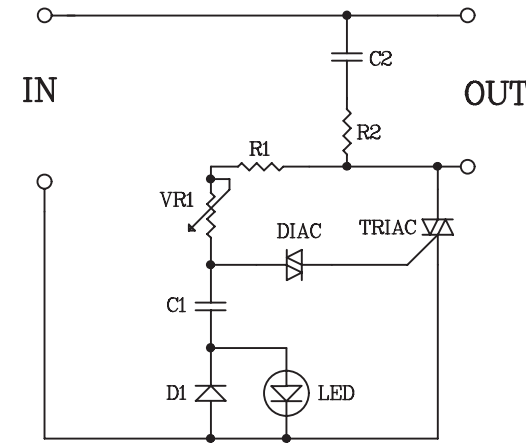
This circuit is applied for adjusting light bulb, electrical stove or pan. But cannot applied for fluorescent light bulb.

**Figure 1. Installing the components**



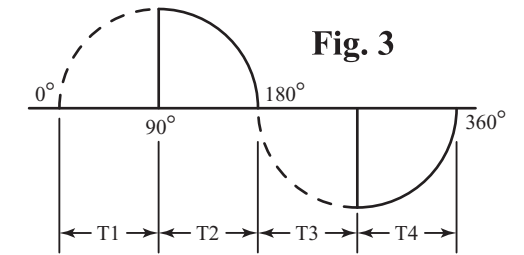
**Troubleshooting:**

The most problem like the fault soldering. Check all the soldering joint suspicious. If you discover the short track or the short soldering joint, re-solder at that point and check other the soldering joint. Check the position of all component on the PCB. See that there are no components missing or inserted in the wrong places. Make sure that all the polarised components have been soldered the right way round.

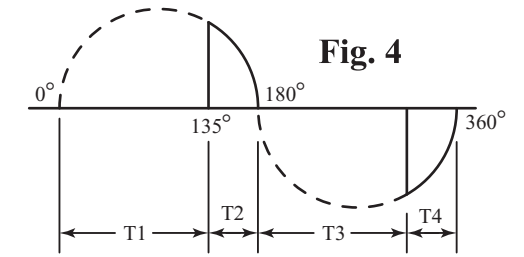


**Figure 2.**

**The AC motor dimmer 1000 watt circuit**

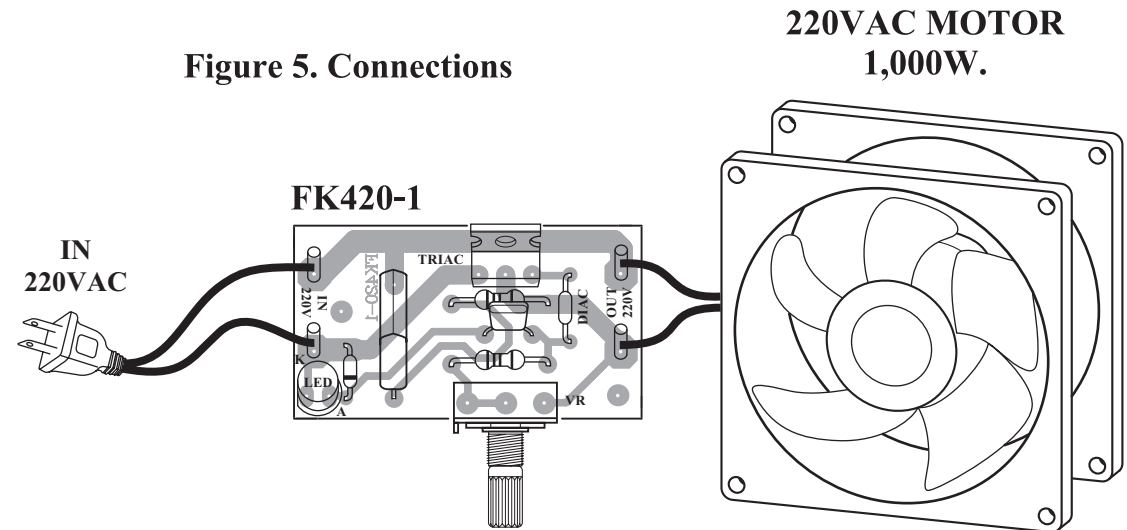


**Fig. 3**

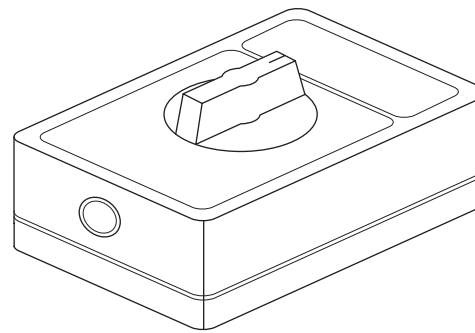


**Fig. 4**

**Figure 5. Connections**



**220VAC MOTOR**  
**1,000W.**



**NOTE:**

FUTURE BOX FB14 is suitable for this kit.

**NEW KIT SET**

| CODE FK | DESCRIPTION                                   | POWER   |
|---------|---|---------|
| 161     | FEELING FLASHER 14 LED                        | 9-12VDC |
| 162     | SATURN'S RING FLASHER 31 LED                  | 9-12VDC |
| 163     | UNIVERSAL FLASHER 10 LED                      | 9VDC    |
| 164     | XENON TUBE FLASHER (STRAIGHT TYPE)            | 220VAC  |
| 165     | SOUND ACTIVATED XENON FLASHER (STRAIGHT TYPE) | 220VAC  |
| 166     | LIGHT ACTIVATED XENON FLASHER (STRAIGHT TYPE) | 220VAC  |